

# Makita

アメリカ

## Cordless Equine Rasp

**MODEL 4399D**  
**MODEL 4399DW**  
With Fast Charger

### INSTRUCTION MANUAL

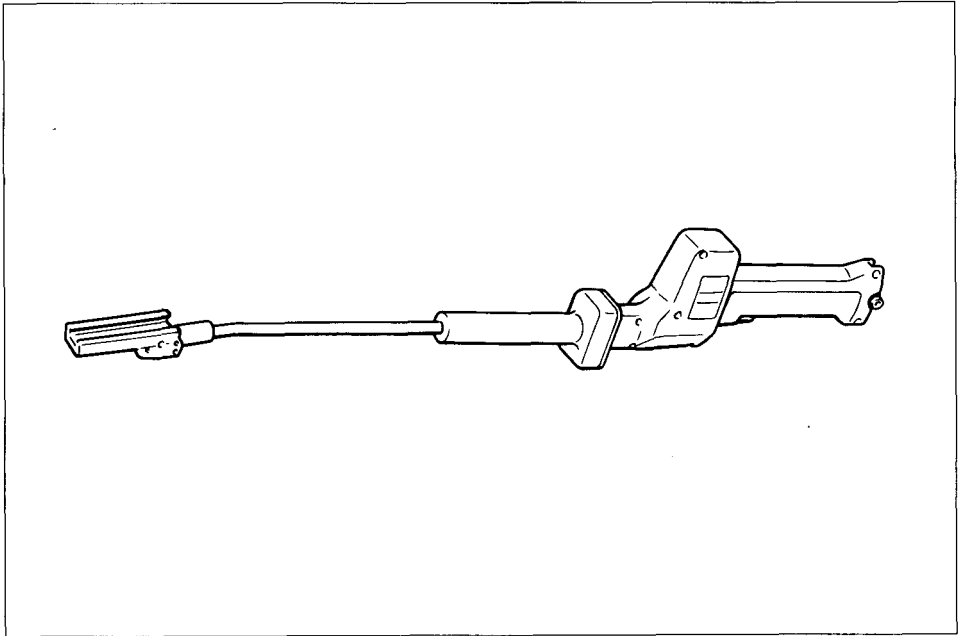

#### SPECIFICATIONS

• Model 4399D

Length of stroke	Strokes per minute	Dimensions (L x W x H)	Net weight
4 mm (5/32")	2,700	847 mm x 61 mm x 137 mm (33-11/32" x 2-13/32" x 5-13/32")	2.4 kg (5.3 lbs)

• Battery Cartridge 9000

• Model DC9700 Fast Charger

Voltage	Input	Output	Charging time
9.6 V	A.C. only 50 Hz – 60 Hz	D.C. 7.2 V – 9.6 V	1 Hr.

\* Manufacturer reserves the right to change specifications without notice.

\* Note: Specifications may differ from country to country.

# **IMPORTANT SAFETY INSTRUCTIONS**

## **(For All Tools)**

**WARNING: WHEN USING ELECTRIC TOOLS, BASIC SAFETY PRECAUTIONS SHOULD ALWAYS BE FOLLOWED TO REDUCE THE RISK OF FIRE, ELECTRIC SHOCK, AND PERSONAL INJURY, INCLUDING THE FOLLOWING:**

### **READ ALL INSTRUCTIONS.**

1. **KEEP WORK AREA CLEAN.** Cluttered areas and benches invite injuries.
2. **CONSIDER WORK AREA ENVIRONMENT.** Don't use power tools in damp or wet locations. Keep work area well lit. Don't expose power tools to rain. Don't use tool in presence of flammable liquids or gases.
3. **KEEP CHILDREN AWAY.** All visitors should be kept away from work area. Don't let visitors contact tool or extension cord.
4. **STORE IDLE TOOLS.** When not in use, tools should be stored in dry, and high or locked-up place — out of reach of children.
5. **DON'T FORCE TOOL.** It will do the job better and safer at the rate for which it was intended.
6. **USE RIGHT TOOL.** Don't force small tool or attachment to do the job of a heavy-duty tool. Don't use tool for purpose not intended.
7. **DRESS PROPERLY.** Don't wear loose clothing or jewelry. They can be caught in moving parts. Rubber gloves and non-skid footwear are recommended when working outdoors. Wear protective hair covering to contain long hair.
8. **USE SAFETY GLASSES.** Also use face or dust mask if cutting operation is dusty.
9. **DON'T ABUSE CORD.** Never carry tool by cord or yank it to disconnect from receptacle. Keep cord from heat, oil, and sharp edges.
10. **SECURE WORK.** Use clamps or a vise to hold work. It's safer than using your hand and it frees both hands to operate tool.
11. **DON'T OVERREACH.** Keep proper footing and balance at all times.
12. **MAINTAIN TOOLS WITH CARE.** Keep tools sharp and clean for better and safer performance. Follow instructions for lubricating and changing accessories. Inspect tool cords periodically and if damaged, have repaired by authorized service facility. Inspect extension cords periodically and replace if damaged. Keep handles dry, clean, and free from oil and grease.
13. **DISCONNECT TOOLS.** When not in use, before servicing, and when changing accessories, such as blades, bits, cutters.

14. **REMOVE ADJUSTING KEYS AND WRENCHES.** Form habit of checking to see that keys and adjusting wrenches are removed from tool before turning it on.
15. **AVOID UNINTENTIONAL STARTING.** Don't carry plugged-in tool with finger on switch. Be sure switch is OFF when plugging in.
16. **OUTDOOR USE EXTENSION CORDS.** When tool is used outdoors, use only extension cords intended for use outdoors and so marked.
17. **STAY ALERT.** Watch what you are doing, use common sense. Don't operate tool when you are tired.
18. **CHECK DAMAGED PARTS.** Before further use of the tool, a guard or other part that is damaged should be carefully checked to determine that it will operate properly and perform its intended function. Check for alignment of moving parts, binding of moving parts, breakage of parts, mounting, and any other conditions that may affect its operation. A guard or other part that is damaged should be properly repaired or replaced by an authorized service center unless otherwise indicated elsewhere in this instruction manual. Have defective switches replaced by authorized service center. Don't use tool if switch does not turn it on and off.
19. **GUARD AGAINST ELECTRIC SHOCK.** Prevent body contact with grounded surfaces. For example; pipes, radiators, ranges, refrigerator enclosures.
20. **REPLACEMENT PARTS.** When servicing, use only identical replacement parts.

**VOLTAGE WARNING:** Before connecting the tool to a power source (receptacle, outlet, etc.) be sure the voltage supplied is the same as that specified on the nameplate of the tool. A power source with voltage greater than that specified for the tool can result in **SERIOUS INJURY** to the user — as well as damage to the tool. If in doubt, **DO NOT PLUG IN THE TOOL.** Using a power source with voltage less than the nameplate rating is harmful to the motor.

# IMPORTANT SAFETY INSTRUCTIONS

1. **SAVE THESE INSTRUCTIONS** — *This manual contains important safety and operating instructions for battery charger.*
2. Before using battery charger, read all instructions and cautionary markings on (1) battery charger, (2) battery, and (3) product using battery.
3. **CAUTION** — To reduce risk of injury, charge only MAKITA Battery 7000, 9000 or 9100. Other types of batteries may burst causing personal injury and damage.
4. Do not expose charger to rain or snow.
5. Use of an attachment not recommended or sold by the battery charger manufacturer may result in a risk of fire, electric shock, or injury to persons.
6. To reduce risk of damage to electric plug and cord, pull by plug rather than cord when disconnecting charger.
7. Make sure cord is located so that it will not be stepped on, tripped over, or otherwise subjected to damage or stress.
8. An extension cord should not be used unless absolutely necessary. Use of improper extension cord could result in a risk of fire and electric shock. If extension cord must be used, make sure:
  - a. That pins on plug of extension cord are the same number, size, and shape as those of plug on charger;
  - b. That extension cord is properly wired and in good electrical condition; and
  - c. That wire size is at least as large as the one specified in the table below.

**TABLE 1**  
**RECOMMENDED MINIMUM AWG SIZE FOR**  
**EXTENSION CORDS FOR BATTERY CHARGERS**

Length of Cord (Feet)	25	50	100	150
AWG Size of Cord	18	18	18	16

9. Do not operate charger with damaged cord or plug — replace them immediately.
10. Do not operate charger if it has received a sharp blow, been dropped, or otherwise damaged in any way; take it to a qualified serviceman.
11. Do not disassemble charger or battery cartridge; take it to a qualified serviceman when service or repair is required. Incorrect reassembly may result in a risk of electric shock or fire.
12. To reduce risk of electric shock, unplug charger from outlet before attempting any maintenance or cleaning. Turning off controls will not reduce this risk.

## **ADDITIONAL SAFETY RULES FOR CHARGER & BATTERY CARTRIDGE**

1. Do not charge Battery Cartridge when temperature is BELOW 10°C (50°F) or ABOVE 40°C (104°F).
2. Do not attempt to use a step-up transformer, an engine generator or DC power receptacle.
3. Do not allow anything to cover or clog the charger vents.
4. Always cover the battery terminals with the battery cover when the battery cartridge is not used.
5. A battery short can cause a large current flow, overheating, possible burns and even a breakdown.
  - (1) Do not touch the terminals with any conductive material.
  - (2) Avoid storing battery cartridge in a container with other metal objects such as nails, coins, etc.
  - (3) Do not expose battery cartridge to water or rain.
6. Do not store the tool and Battery Cartridge in locations where the temperature may reach or exceed 50°C (122°F).
7. Do not incinerate the Battery Cartridge even if it is severely damaged or is completely worn out. The battery cartridge can explode in a fire.

## **ADDITIONAL SAFETY RULES**

1. This tool is to be used solely for rasping horses' teeth. Do not use it for other purposes.
2. This tool must be used in conformity with all applicable health, hygienic, safety and veterinary regulations involved when rasping horse teeth.
3. Before each use, be sure to sterilize the rasp blade, holder and drive shaft. When rasping teeth of a number of horses, sterilization of these parts before doing each horse is important to prevent the spread or cross infection of any disease, virus, etc.
4. Before use, make sure that all bolts securing the rasp blade or holder are tight.
5. Do not run the motor in the horse's presence before rasping as it is a new noise and may startle the horse.
6. After use, clean off the rasp blade using the brush provided. Cleaning helps maintain efficiency and assures longer life of the tool.

**SAVE THESE INSTRUCTIONS.**

## Installing or removing battery cartridge

- Always switch off the tool before insertion or removal of the battery cartridge.
- To remove the battery cartridge, pull out the set plate on the tool and grasp both sides of the cartridge while withdrawing it from the tool.
- To insert the battery cartridge, align the tongue on the battery cartridge with the groove in the housing and slip it into place. Snap the set plate back into place. Be sure to close the set plate fully before using the tool.
- Do not use force when inserting the battery cartridge. If the cartridge does not slide in easily, it is not being inserted correctly.

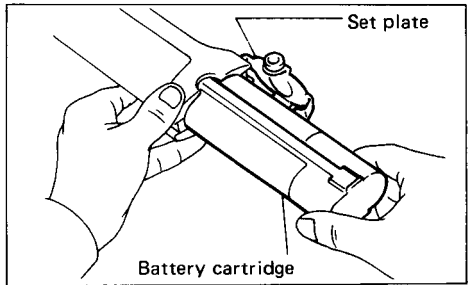

## Charging

Plug the fast charger into your power source. Insert the battery cartridge so that the plus and minus terminals on the battery cartridge are on the same sides as their respective markings on the fast charger. Insert the cartridge fully into the port so that it rests on the charger port floor.

Press the start button (red). The charging light will come on and charging will begin.

If the charging light does not come on, press the reset button (yellow) first, then the start button (red). If the charging light goes out within 10 seconds even after pressing the reset button and start button a couple of times, the battery cartridge is dead. (CAUTION: Wait for more than 5 seconds after the charging light goes out to press the reset button again.) Replace it with a new one. When the charging light goes out after about one hour, you may remove the fully charged battery cartridge.

After charging, unplug the charger from the power source.

## CAUTION:

- Your new battery cartridge is not charged. You will need to charge it before use.
- Do not keep the button pressed in with tape, etc. or the circuit will not function properly. Also, a malfunction of the charger may result possibly causing overheating, etc.
- If you try to charge a cartridge from a just-operated tool, sometimes the charging light will not come on. If this occurs, let the cartridge cool off for a while. Then re-insert it and try to charge it once more.
- When you charge a new battery cartridge or a battery cartridge which has not been used for a long period, it may not accept a full charge. This is a normal condition and does not indicate a problem. You can recharge the battery cartridge fully after discharging it almost completely a couple of times.
- If you wish to charge two battery cartridges, allow 15 minutes between chargings on the fast charger.

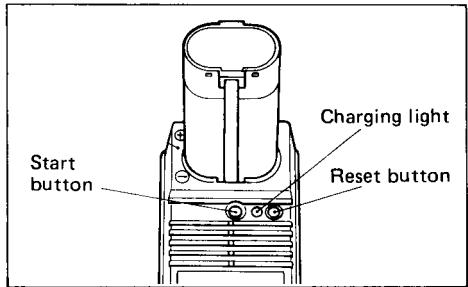

## Installing or removing/adjustment of rasp blade and holder

### CAUTION:

- Always be sure that the tool is switched off and the battery cartridge is removed before installing or removing/adjustment of the rasp blade and holder.
- Always be sure that all bolts which secure the rasp blade or holder are securely tightened before use.

1. Use an 82 mm x 25 mm x 3 mm rasp blade which is available on the market.
2. To install the rasp blade, slide into the holder up to the stop and tighten both securing bolts using the hex wrench.

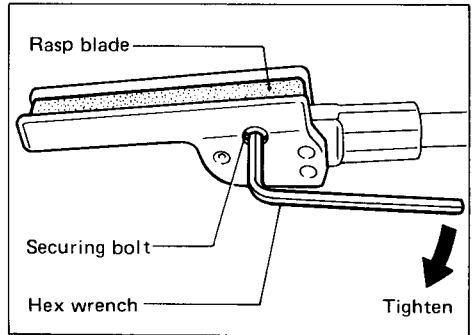

3. The holder is held on the drive shaft with the rasp blade facing upward. If you wish to re-install the holder on the drive shaft with the rasp blade facing downward, proceed as follows.

- i) Loosen the securing bolt using the hex wrench and pull the holder out of the drive shaft.
- ii) Turn the holder upside down and insert it into the drive shaft.
- iii) Tighten the securing bolt using the hex wrench after aligning the securing bolt with the notch on the drive shaft.

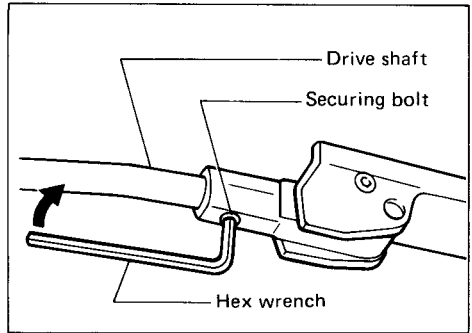

4. In normal use the holder is used in the flat position: for the first premolar the holder is angled. The holder is activated by pressing the spring loaded trigger and moving to the position required and then releasing the trigger.

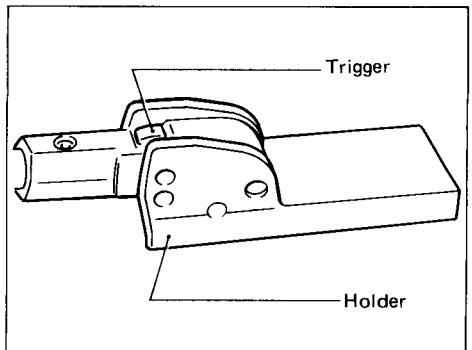

After use, return the hex wrench to the storage position.

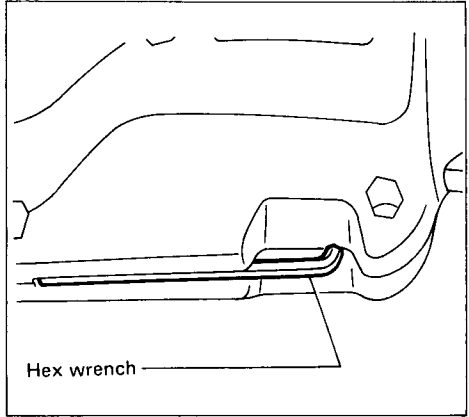

### Switch action

To prevent the trigger from being accidentally pulled, a lock-off lever is provided. To start the tool, slide the lock-off lever in the direction of the arrow and pull the trigger. Release the trigger to stop.

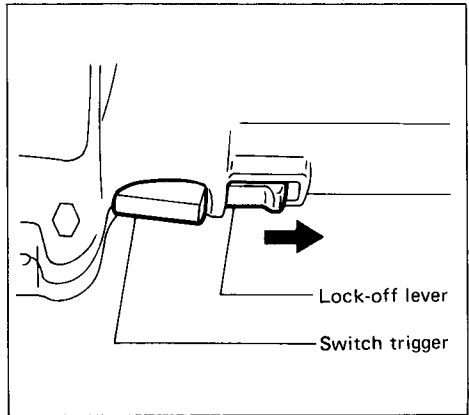

### CAUTION:

Before inserting the battery cartridge into the tool, always check to see that the trigger switch actuates properly and returns to the "OFF" position when released.

### Sterilization of rasp blade, holder and drive shaft

The rasp blade, holder and drive shaft must be sterilized each time the tool is used and between each horse, to prevent the spread or cross infection of any disease, virus, etc. They can be sterilized by boiling or in a disinfectant (which will not harm the horse's health) without removing them from the tool. But it is recommended rather that the sterilization be carried out by a suitable sterilizing unit after removal from the tool. In this case, the hex wrench to be used for assembling them also must be sterilized.

### CAUTION:

When sterilizing the rasp blade, holder and drive shaft by boiling or in a disinfectant, be careful not to splash boiling water or disinfectant on your hands, the tool, etc.



## **Operation**

### **CAUTION:**

- The rasp blade, holder and drive shaft must be sterilized each time the tool is used and between each horse, to prevent the spread or cross infection of any disease, virus, etc.
  - Do not run the motor in the horse's presence before rasping as it is a new noise and may startle the horse.
  - At all times while rasping, watch the horse's facial expressions.
1. Rack a horse you are familiar with when using the tool for the first time.
  2. Position the horse the same way you would for hand rasping.
  3. Begin by using the tool to rasp the horse's teeth manually. Then switch it ON after a while.
  4. If the horse becomes upset after you begin rasping, switch the tool OFF but keep the rasp blade contacting the teeth and continue to rasp manually. Never remove the tool from the horse's mouth.
  5. Once the horse calms down, switch ON again. Repeat the above procedure (steps 3-4) until the horse gradually becomes accustomed to rasping with the tool.

## **MAINTENANCE**

### **CAUTION:**

Always be sure that the tool is switched off and the battery cartridge is removed before attempting to perform inspection or maintenance.

### **WARNING:**

- As stated previously, this tool must be used in conformity with all applicable health, hygienic, safety and veterinary regulations involved when rasping horse teeth. Makita shall not be liable for any claims arising from the use or misuse of this tool.
- Regulations for the use of a tool to rasp horses' teeth may vary from country to country. If you are not sure of the applicable regulations, consult a local veterinarian or the relevant local authorities. The health of the horse is of paramount importance.

To maintain product SAFETY and RELIABILITY, repairs, maintenance and adjustment should be performed by Makita Authorized or Factory Service Centers, always using Makita replacement parts.

## ACCESSORIES

### CAUTION:

These accessories or attachments are recommended for use with your Makita tool specified in this manual. The use of any other accessories or attachments might present a risk of injury to persons. The accessories or attachments should be used only in the proper and intended manner.

- **Battery cartridge 9000**

Part No. 632009-0

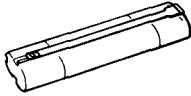

- **Fast charger**

Model DC9700

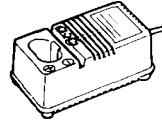

- **Charger 12V for car**

Model DC9112

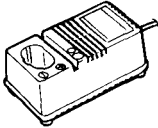

- **Hex wrench 3**

Part No. 783201-2



- **Battery cover**

Part No. 414938-7



# CORDLESS EQUINE RASP Model 4399D

**Type1**

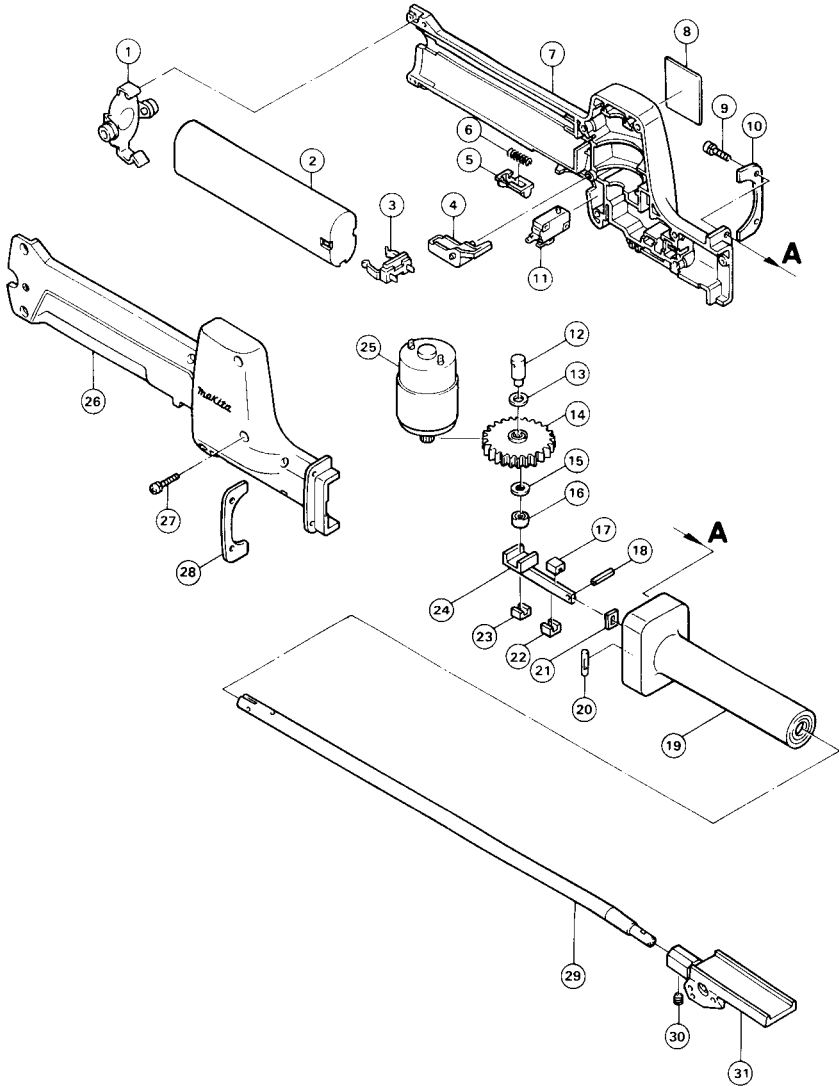

Note: The switch and other part configurations may differ from country to country.

アメリカ

MODEL 4399D

Jan.-22-'93 EN

ITEM NO.	NO. USED	DESCRIPTION	ITEM NO.	NO. USED	DESCRIPTION
<b>MACHINE</b>			<b>MACHINE</b>		
1	1	Set Plate	17	1	Plane Bearing 3
2	1	Battery 9000	18	1	Spring Pin 5-12
3	1	Battery Holder	19	1	Rod Holder
4	1	Trigger	20	1	Pin 4
5	1	Lock-Off Lever	21	1	Felt
6	1	Compression Spring 3	22	1	Plane Bearing 3
7	1	Housing Set (With Item 26)	23	1	Plane Bearing 3
8	1	Name Plate	24	1	Slider
9	4	Hex. Socket Head Bolt M4x16 (With Washer)	25	1	DC Motor 9.6 V.
10	1	Support Plate	26	1	Housing Set (With Item 7)
11	1	Switch	27	8	Pan Head Screw M4x22 (With Washer)
12	1	Supporter A	28	1	Support Plate
13	1	Flat Washer 7	29	1	Rod 12
14	1	Gear	30	3	Hex. Socket Head Bolt M6x6
15	1	Thin Washer 6	31	1	Holder
16	1	Needle Bearing 607			

Note: The switch and other part specifications may differ from country to country.

## MAKITA LIMITED ONE YEAR WARRANTY

### Warranty Policy

Every Makita tool is thoroughly inspected and tested before leaving the factory. It is warranted to be free of defects from workmanship and materials for the period of ONE YEAR from the date of original purchase. Should any trouble develop during this one-year period, return the COMPLETE tool, freight prepaid, to one of Makita's Factory or Authorized Service Centers. If inspection shows the trouble is caused by defective workmanship or material, Makita will repair (or at our option, replace) without charge.

This Warranty does not apply where:

- repairs have been made or attempted by others;
- repairs are required because of normal wear and tear;
- The tool has been abused, misused or improperly maintained;
- alterations have been made to the tool.

IN NO EVENT SHALL MAKITA BE LIABLE FOR ANY INDIRECT, INCIDENTAL OR CONSEQUENTIAL DAMAGES FROM THE SALE OR USE OF THE PRODUCT. THIS DISCLAIMER APPLIES BOTH DURING AND AFTER THE TERM OF THIS WARRANTY.

MAKITA DISCLAIMS LIABILITY FOR ANY IMPLIED WARRANTIES, INCLUDING IMPLIED WARRANTIES OF "MERCHANTABILITY" AND "FITNESS FOR A SPECIFIC PURPOSE," AFTER THE ONE-YEAR TERM OF THIS WARRANTY.

This Warranty gives you specific legal rights, and you may also have other rights which vary from state to state. Some states do not allow the exclusion or limitation of incidental or consequential damages, so the above limitation or exclusion may not apply to you. Some states do not allow limitation on how long an implied warranty lasts, so the above limitation may not apply to you.

**Makita Corporation**

3-11-8, Sumiyoshi-cho,  
Anjo, Aichi 446 Japan

883842 — 067

PRINTED IN JAPAN  
1993 — 6 — N